



厦门泽瑞进出口有限公司

Tel:+86-592-5616848

5616805

XIAMEN JIREH INDUSTRIAL CO., LTD.

Fax:+86-592- 5616958

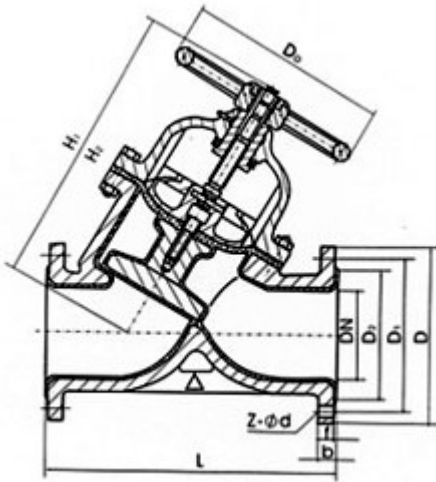

Design & manufacture: GB12239
 Face to face: JB1688, GB12221
 Flange ends: JB78, GB4216
 Test for lining layer: Electro spark detecting
 Test: GB/T13927

Body & Bonnet	Cast Iron, Carbon Steel, Stainless Steel
Lining	Unlined, Fluorine Plastic
Diaphragm	Fluorine Plastic
Disc	Cast Iron, Stainless Steel
Stem	Carbon Steel, Stainless Steel

DN	L	D	D1	D0	n-φd	H	H1	Weight kg
PN10								
25	145	115	85	120	4-14	178	190	
32	160	140	100	140	4-18	196	217	
40	180	150	110	140	4-18	196	217	14
50	210	165	125	200	4-18	219	240	20
65	250	185	145	200	4-18	264	272	29
80	300	200	160	280	4-18	285	315	42
100	350	220	180	320	8-18	352	383	61
125	400	250	210	320	8-18	470	515	79 . 5
150	460	285	240	400	8-22	508	554	150
200	570	340	295	500	8-22	602	660	236 . 5
250	680	395	350	500	12-22	708	786	
300	790	445	400		12-22			

1105 Block B Yucheng Bldg., No. 51 Dongdu Road, Xiamen, China

E-mail: jireh@jirehvalve.com

<http://www.jirehvalve.com>